



& (J 0 @ H 5 @ H 9 F B 5 H C F



▪ \$0 AMP

**HIGH
OUTPUT
ALTERNATOR**

**SPECIFICATION
SHEET**

o" # 06 †

SMART BATTERY CHARGER

17779 Main Street, Suite C
Irvine, CA 92614

Tel: +1 (949) 333-3800

Fax: +1 (949) 333-3804

www.SmartBatteryCharger.net

ALTERNATOR DESCRIPTION

The supplied alternator is a component of a next generation high efficiency, severe duty charging system designed to be used in Dual Alternator configurations as well as an OEM replacement for many engines. This system consists of a 300 amp 24 volt alternator. The alternator produces a maximum of 300 amps and a minimum of 215 amps at low idle speeds.

TECHNOLOGY

This alternator is an integral charging system that incorporates an innovative brushless design. It is air cooled and maintains high amperage output at all critical speed ranges.

MOUNTING

The alternator is specially designed to mount using our Dual Alternator Mounting Brackets or as an OEM replacement for specific engines.

ALTERNATOR DURABILITY

The supplied charging system is manufactured to the highest quality standards. It is designed and manufactured in the USA using only components made in the USA and/or Japan. All parts are carefully chosen and used for their durability, dependability and proven performance in the field.

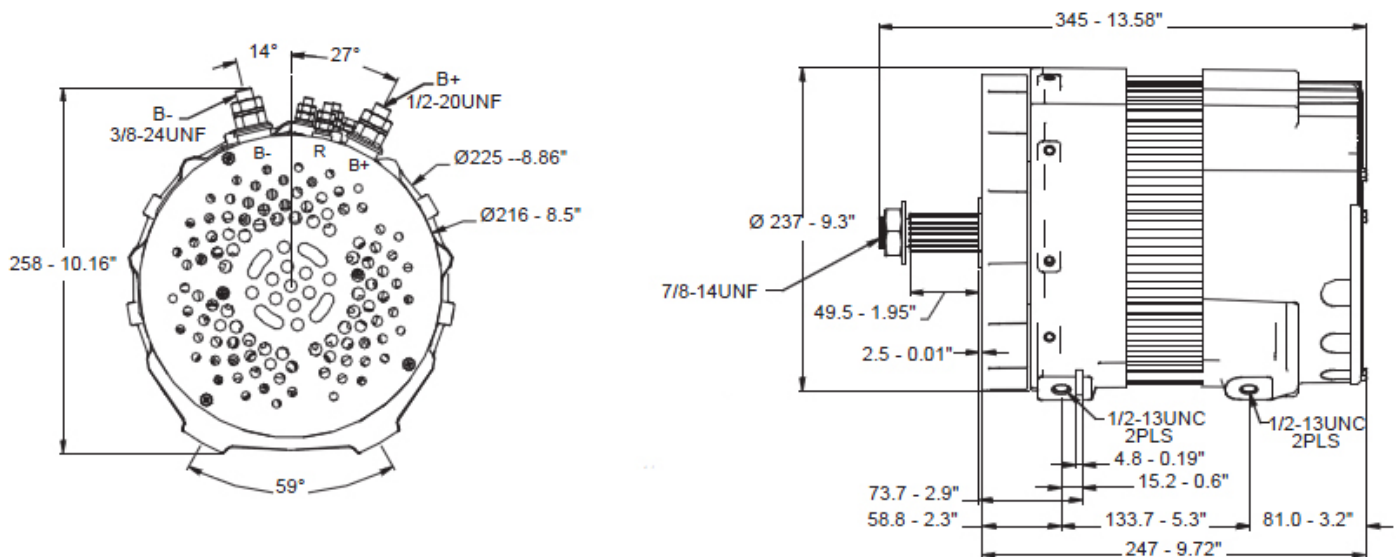

SMART BATTERY CHARGER

17779 Main St Suite C, Irvine, CA 92614
Phone: +1 (949) 333-3800 Fax: +1 (949) 333-3804
www.SmartBatteryCharger.net

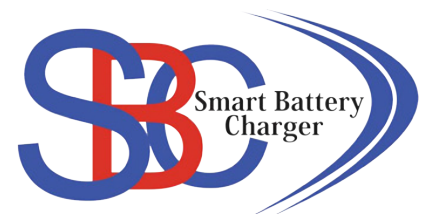

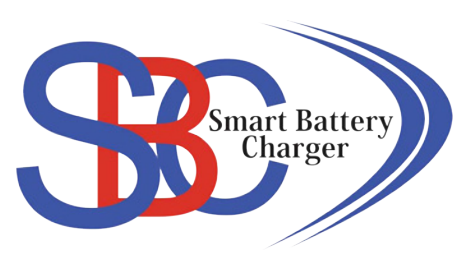

Part Number: SBC-300XP-24V

Description	High Output Alternator
Availability	In Stock
Volts	24
Amps @ Engine Idle	215
Maximum Amps	300
Mounting Style	Direct Fit to OEM Mounting / Dual Mount
Cooling Style	Air Cooled
Regulator	Solid State with Load Dump Protection
Terminals	R Terminal for Tachometer D+ Terminal for Indicator Light (Optional) S Terminal for External Sensing (Optional)
Negative	Ground
Excitation	Self-excited
Shipping Weight	80 lbs / 36.3 kg

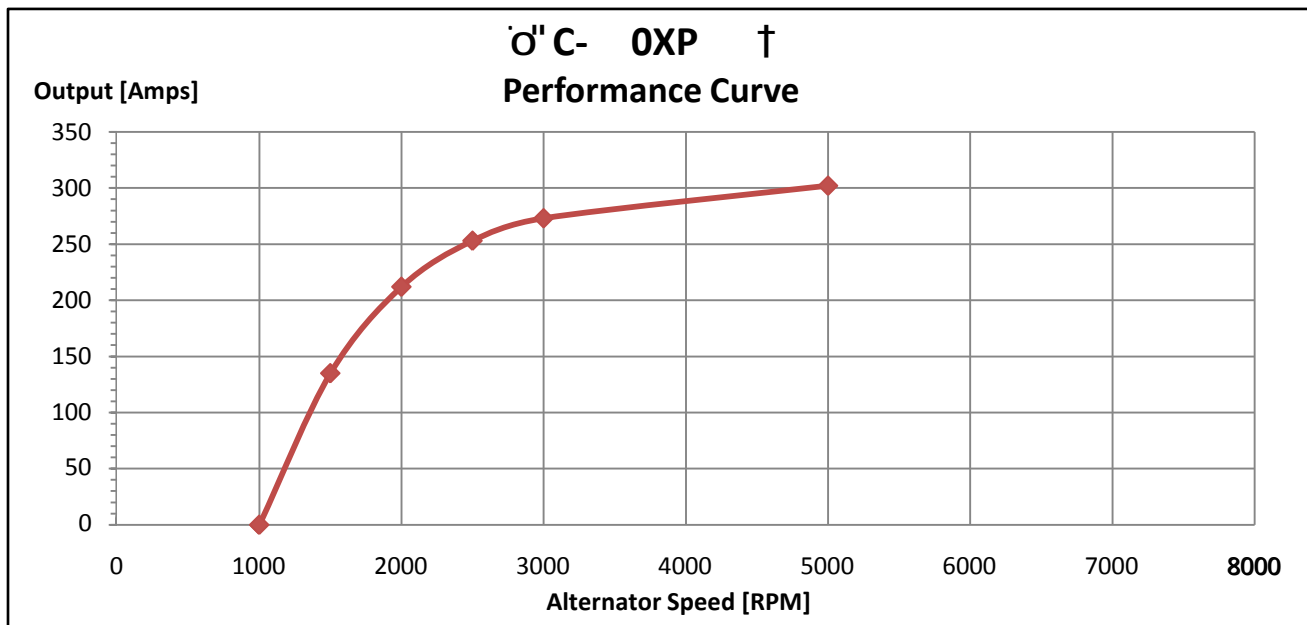

We reserve the right to change or modify the contents of this document and/or the functionality of the Alternator without notice.

Smart Battery Charger

17779 Main St Suite C, Irvine, CA 92614

Phone: +1 (949) 333-3800 Fax: +1 (949) 333-3804

www.SmartBatteryCharger.net